



Isolators & Gloveboxes

Secure your environment
by **protecting** products and users





The unique performance of PIERCAN Isolators & Gloveboxes

PIERCAN's flexible isolators and gloveboxes guarantee airlocked intervention spaces with a controlled atmosphere. They can be connected to other containment devices and are interchangeable on new and existing installations.



Quick and easy
implementation



Great flexibility
in use and
handling



Effective barrier
against pollutants
and contaminants



Compatible with
cleaning agents and
surface decontamination



More economical
and **lighter** compared
to a rigid isolator

Areas of Application



UNIVERSITY - RESEARCH



NUCLEAR



FOOD INDUSTRY



Available options

They are available with or without structures and accessories

Materials

PVC CRYSTAL PVC PUR EBA/EVA

SOFT ISOLATOR

HEALTH - PHARMACEUTICAL VETERINARY HEALTH-HOSPITAL

It is a **working enclosure** with flexible, transparent walls, which offers a **panoramic view** of the environment. Ideal when protection against materials, sensitizers or chemical compounds is required as it provides respiratory and skin protection. It corresponds mainly to the needs in the field of "health-pharmaceutical" but also in the "hospital-health" and "University-research" sectors.

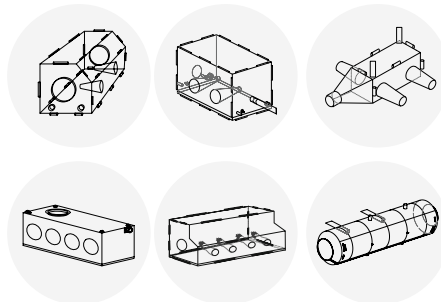
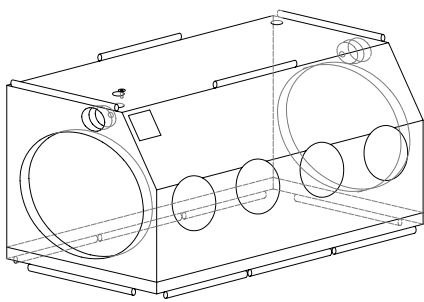

OPTIONS

- Wide possibility to customize
- Quality calendered and crystal plastic sheets to guarantee a good optical quality
- Waterproof closure possible*

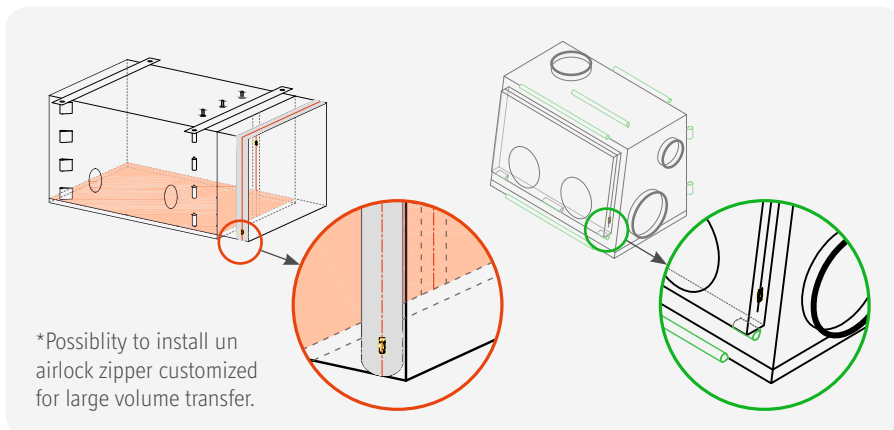

*Possibility to install an airlock zipper customized for large volume transfer.

INTERVENTION GLOVEBOX

NUCLEAR POLICE

It is a **flexible**, multifunctional **walled glovebox** made of a semi-rigid non-metallic structure of high quality engineered plastic films. Assembled **in minutes**, it can be **mountable and removable** very quickly **everywhere**. **Transportable** and **lightweight**, it can meet requirements of laboratory or field work in Nuclear and Health sectors.

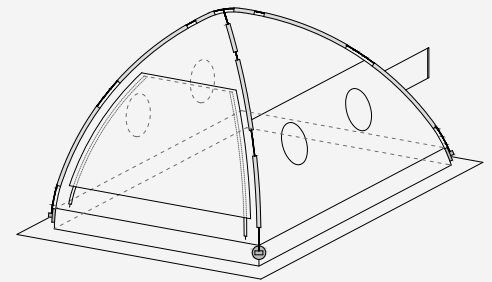

OPTIONS

- Wide possibility to customize
- Quality calendered and crystal plastic sheets to guarantee a good optical quality

Accessories for Flexible Isolator

The isolator accessories are made of colored or transparent plastic sheets, with or without support. They have good mechanical properties and are impervious to liquids and low concentration chemicals.



TUNNEL

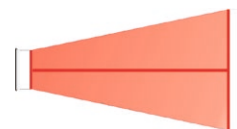

HANDLING SLEEVE



"INTERNAL" CAP
with seal



"EXTERNAL" CAP
without seal

From the design to the realized part of **flexible isolators and gloveboxes**

From the start of your project, **PIERCAN** brings you the right solution, via a controlled process – design, manufacturing, control – where quality is at the core of all processes.

THE DESIGN



• Engineering Office

Analyzes your requests and accompanies you in the search for the most suitable solution including choice of material, product development, and prototyping.

• Economic Optimization

The study of solutions integrates both quality factors, time and production costs, thus facilitating economic optimization of your project.

MANUFACTURING

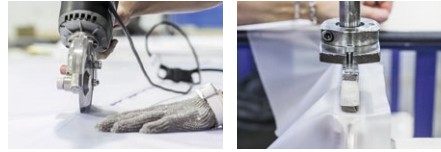

• Cut

Scissors with circular blades and vibrating blades are used for semi-automatic cutting (unit cut to pattern, mattress format or a template).

• Weld

Made by high frequency welding which guarantees a perfect seal of the assemblies.

• Properties

Compatible with cleaning agents, decontamination and disinfection.

CONTROL IN THREE STEPS



1 • Incoming inspection of raw materials and tools with verification of design dimensions via our production management software.

2 • Control during production of physio-chemical parameters by the quality control laboratory and production parameters by the operators.

3 • Control of the finished product

- Sealing control
- Weld control
- Marking allowing the identification of the controlled part for a total traceability.

PIERCAN around the world



Piercan US Office • Factory
San Diego

USA



Piercan Commercial Management • Factory
Paris

France



Piercan Headquarter • Factory
Normandy

France

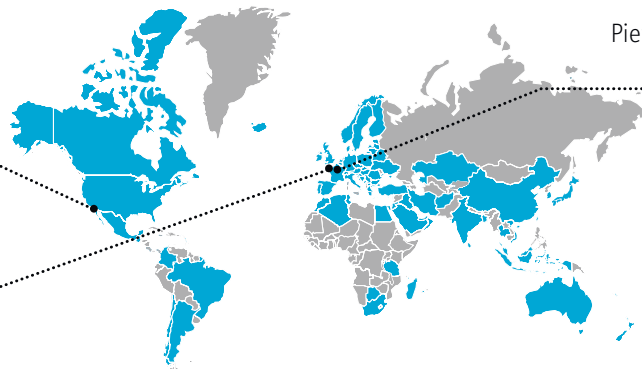

■ Piercan products are sold in more than 50 countries



A QUESTION OR IN NEED OF INFORMATION?

Please do not hesitate to contact our sales team by phone or email.
Piercan's services and products are only one call away:

☎ **Telephone** +33 (0)1 45 88 66 27 (FR)
+1 (760) 599 4543 (USA)

✉ **E-mail** piercan@piercan.com



PIERCAN FRANCE

Impasse des Macareux
14520 Port-en-Bessin-Huppain - FRANCE
T +33 (0)1 45 88 66 27
piercan@piercan.com | www.piercan.com

PIERCAN USA, INC.

160 Bosstick Blvd
92069 San Marcos, CA - USA
T +1 (760) 599 4543
piercan@piercan.com | www.piercan.com

